

<https://doi.org/10.21272/mmi.2020.3-07>

JEL Classification: D12, J24, M13

Chiraz Rouissi,

Dr. Sc., Associate Professor; University of Jeddah, Saudi Arabia

 ORCID ID, 0000-0002-6363-2262

email: charrouissi@yahoo.fr

Correspondence author: charrouissi@yahoo.fr

USER SATISFACTION AND INFORMATION SYSTEM: CASE FOR AN EMERGING COUNTRY

Abstract. Every corporate always tries to set up an information system to meet its specific needs. Not long ago, information was synonymous with power. Thus, holding it was often seen as a positive value. Today it must not only irrigate the company but also spread within it, intended for customers, suppliers, stakeholders and even shareholders. This paper summarizes the use of the management software that automates all company functions and integrates all functionalities that are necessary for its management and production. The main purpose of this article is to show a question on identifying corporate management to determine the potential impact of the information system and communication on the quality and the utility of the management of users' satisfaction. The object of research is 214 companies with different activities related to the information system and communication. Thus, in recent years the business environment has not stopped experiencing changes and mutations at all levels as economic, sociological or technological. In turn, the paramount importance granted by firms to information technology and communication to be able to face increased competition and thus improve their competitive positioning. The research empirically confirms and theoretically proves many advantages of this study. Therefore, informational benefits help companies to manage resources better, improve decision-making and planning and better perform in the company departments. The ERP systems can provide information benefits to management using their centralized database and their ability to analyze data. The availability of immediate information and above all, on a national or even international basis, becomes more than necessary. The results of the research can be useful for strategic advantages like ERP systems, with their internal and external integration capabilities. Moreover, they will help organizations to achieve these strategic benefits.

Keywords: corporate, information technology, enterprise resource planning, communication, quality and utility.

Introduction. The information has never had more weight in our society than it does today. The business must continuously adapt to maintain its competitive advantage and be reactive in an uncertain environment and a rapidly changing society.

For this, it is necessary to collect exhaustive information that is relevant both internally and externally. Communication and information system become for the majority of firms a critical factor in their success.

Not long ago, information was synonymous with power and holding it was often seen as a positive value. Today it must not only irrigate the company but also spread within it, intended for customers, suppliers, partners and even shareholders.

This paper summarizes the using management software that automates all company functions and integrates all functionality necessary for its production.

The concept of information system emerged after World War II in response to the information management needs of organizations. The appearance of computer0aided means allows the automation of information management to accelerate reflection on the nature and structure of the «nervous system» of the organization that constitutes information circuits.

Various studies have shown the positive impact of the implementation of the information system on the function of the management controller.

A longitudinal study conducted by Scapens and Jazayeri (2003), within a European division of an American multinational, showed the change of role following the implementation of an ERP (SAP):

Cite as: Rouissi, C. (2020). Information's System and User Satisfaction: Empirical Study in the Context of an Emerging Country. *Marketing and Management of Innovations*, 3, 87-105.
<http://doi.org/10.21272/mmi.2020.3-07>

elimination of routine tasks, use of forward-looking information etc. Granlund and Malmi (2002) observed that following the implementation ERP, the controllers had more time to analyze results and give advice.

Russel, Siegel and Kulesza (1999), found in a study with 294 American financial controllers that financial controllers are the winners of the revolution information technology. It helps and internal customers to produce and use relevant information for decision making. The management controllers would work increasingly with internal users to provide the right decision.

Kaplan (1995) believes that advances in technique and design of control modes should allow controllers to be part of the value creation team to participate in the formulation and implementation of the strategy. The information technologies (IT) supporting the information systems of the companies are not of recent appearance and did not stop evolving.

In this article, users' satisfaction refers to the satisfaction of management controllers, considering the fulfilment of information users as a substitute for measuring the success of information systems (the method used by the majority of researchers in the «management information» field system). These perceptual measures of IS success have therefore been used extensively over several years.

Through this context, this article will first present the emergence, the importance of information system technologies, and the theoretical approach. It will show the different concepts related to information technology such as definitions of information technology, objectives of the information system, perspectives opened by information technology and the characteristics of enterprise systems, the description of the management controller and the value of information systems for the management control. Then, the empirical part of this study presents an explanatory model of its impacts with resulting hypotheses devoted to testing the developed model empirically.

Literature Review. The socio-technical school studies the link between technical and human systems. It starts from the observation that technological changes have a decisive impact on the functioning of groups and on the individuals, who compose them. The introduction of information technologies like ERP (Enterprise Resources Planning) constitutes a social impact because decisions must take into account human factors (qualifications, expectations, feelings, values) and the environment (equipment, machinery, procedures, working hours, working conditions). Besides, the ERP also contributes to improving staff knowledge. Indeed, the introduction of ERP assumes that the users of this new technology must acquire new skills to better handle it. They reach a certain level of confidence and efficiency using ERP, which allows them to improve their productivity. According to Olson and Davis (1985), Defined «implementation as preparing a business to receive an information system to use it effectively». It means that the outcome of the implementation extends to a change in tasks, structures and staff. Information Technology includes the techniques used in the processing and transmission of information, mainly computers, the Internet and telecommunications. IT brings together a set of resources necessary to manipulate information, particularly the computers, programs and networks essential to convert, store, manage, transmit and retrieve it. Already, information technology includes IT, electronics, office automation, telecommunications, and control engineering. According to Reix (2004) «An information system is an organized set of resources: hardware, software, personnel, data, procedures ... making it possible to acquire, process, store information (in the form of data, texts, images, sounds, etc.) in and between organizations».

Information systems (IS) consisted of separate specific applications (Accounting, Production management, commercial management). These various applications could only communicate through interfaces: to improve the exchange of information between the various functions of the company, it was essential to implement integrated systems: these are the integrated management software packages «ERP» (Baglin, 2005).

Information systems make it possible to link strategic intention and operational processes, in particular by modelling processes and creating the new organizational configurations which allow more ambitious strategies and above all make possible the evaluation and control of strategic management.

Many executives are losing interest in driving information systems, reducing them from managing the automation of repetitive operations. The perspectives and characteristics opened by information technologies are reaching the third generation today, and each generation is linked to an organizational logic. The first generation was centralized on computing around microcomputers and hierarchical databases. The principle of this procedure was fixed once and for all. This type of computer corresponded to Taylor's organization of labor, with a dominant center and a partitioned and non-communicating organization. The main purpose of IT was automatic data processing. This possibility of the modular organization is facilitated by the appearance of large software for automating an organization's standard processes, ERP. The characteristics of enterprise systems are business software packages that enable the integration of transactional data and business processes across the entire organization. In fact, business systems include ERP software and related products such as APS (Advanced Planning and Scheduling), sales force automation, CRM (Customer Relationship Management). These business systems have several characteristics that have important implications for organizations that adopt them. The value of information systems for management control is introducing the management controller. It amounts to defining the content of the various activities controller performs, his profile and hierarchical position, knowing that these vary according to the type of organization, their size; their need, their culture.

The management controller, also known as planning and management, exercises permanent control over the company's budgets because it prepares the budget forecast and implements control procedures. Finally, it assists in all areas to enable the optimal use of resources. An information system supports management control function. It doesn't control itself but helps managers in their planning and control activities. The objectives of some system designers is to develop a fully integrated information system, into which each source piece of information would enter only once before being combined in various ways to provide the essential summaries of decision makers. The information system can be developed for a specific division or type of task, such as CAPE (Computer-Aided Production Management). The dream of every decision-maker remains the integration of all the IT tools of a company. The system is comprehensive in the sense that all of the organization's significant resources are under the control of the decision-maker. The contingency theory shows that the interest given to management controllers is dependent on several factors including the activity of the company, the uncertainty attached to the environment, the size of the company, and the behaviour and hierarchical position of management controllers. The behaviour of the management controller differs according to the size of the company. The management controller of an SME, which only has an embryonic information system, uses little accounting data, believing that it is capable of managing its affairs on its own, trusting mainly to his intuition. On the other hand, if the company is big, the decision-making will be more critical, and the process tends to be structured through the use of formalized techniques. Ives, Olson and Baroudi (1983) developed a differential instrument measuring the overall satisfaction of computer users who tried to refine and shorten it to arrive at a 13-items tool which, nevertheless, presented specific methodological and conceptual difficulties.

Dependent variables: User Satisfaction (Management Controllers).

In literature, the dimension has been widely used as a variable depending on the success and effectiveness of IS. Indeed, Delone and Mc Lean (1992) note several 33 empirical works published between 1981 and 1987, which assess the success in terms of user satisfaction. However, what should be noted in this regard is that there is no consensus on a single conceptual definition of the variable «user satisfaction». This variable was associated with several terms such as: «felt need», «acceptance of the system», «perceived usefulness», «feelings». Bailey and Pearson (1983) defined satisfaction as «the sum of feelings and attitudes towards a variety of factors affecting the situation». In turn, Seddon and Kiew (1996) described satisfaction as «the «clear» feeling of pleasure or dissatisfaction that results from an aggregation of all the benefits that a person hopes to receive from interaction with the information system».

Such measurement instruments have been mainly based on the satisfaction of users of information or «User information satisfaction» (UIS) as being a substitute for measuring the success of SI.

Independent variables: Variables explaining user satisfaction:

To explain and present the various explanatory variables that can affect user satisfaction, and which are therefore introduced into the conceptual model.

1. The quality of information: this concept has been widely used as a critical success factor in IS research. In fact, according to specific authors, it constitutes one of the measures of satisfaction. It therefore generally includes attributes relating to the quality of the information provided by the ERP such as the format of the information, its clarity, its accuracy, its content, availability on time, etc.

Consequently, hypothesis (H1) stipulates that: «The quality of the information has a positive impact on user satisfaction's».

2. The quality of the system: this dimension constitutes a powerful determinant of the efficiency of IS as well as user satisfaction (Bessire, 1995). The quality of the system relates to the quality of the application itself (the different functionalities of the system, ease of use and learning).

Therefore, the second hypothesis (H2) of this thesis will be: «The quality of the system has a positive impact on user satisfaction's».

3. The utility perceived by users: this dimension was considered by F. Davis (1989) to be a factor affecting user satisfaction because it includes, on the one hand, items relating to perceived ease of use and, on the other hand, those relating to the perceived utility. Besides, this author shows that the acceptance of a technology depends on the perceptions of users of this technology. Therefore, this makes it possible to advance the third hypothesis (H3), titled: «The utility of the system has a positive impact on user satisfaction's».

4. The communication: the quality of communication in working groups plays an essential role in the attitude of employees towards change. Jones et al. (2006), Bendoly et al. (2006) are often not welcomed with open arms by workers who are used to familiar systems and do not want to change them. So, good communication is vital for the success of any project and especially a large-scale project of the implementation of an ERP system, hence the hypothesis (H4) according to which: «The communication has a positive impact on user satisfaction's».

Methodology and research methods. The data obtained from the survey was analyzed using SPSS and AMOS software. This software makes it possible to describe the data and to carry out all the desired analyzes: flat sorting and multidimensional methods (factorial analysis, joint analysis, analysis of variance, structural equation method). This research chose as mother population a Tunisian population with different profiles of 214 corporate from different sectors of activities.

This paper followed the recommendations of Roussel et al. (2002), where the sample size must satisfy certain conditions to determine the size of the study's sample. On the one hand, these are the number of items and latent variables in the theoretical model. On the other hand, it is the number of covariances in the data matrix. It also depends on the method of estimating the theoretical model. Thus, the minimum size of the sample must exceed the number of covariances in the data matrix. The maximum size is suitable for a ratio of ten observations per estimated parameter. Besides, the use of the maximum likelihood method in confirmatory factor analyzes requires medium-sized samples. Consequently, it chose a convenience sample made up of 214 interviewees with different profiles. As part of this study, the research performed simple sorts to determine the distinctive elements of the sampling units that made up the sample describing the company (Sector of activity, etc.), on the one hand, and the interviewees (age, gender, experience on work, etc.), on the other hand. Table 2 summarizes the characteristics of the companies in the sample: The structure of the sample was expressed according to many criteria. Compared to the sector of activity criterion, most of the companies (30.4%) in the sectors are from the food industry sectors.

Table 1. Description of the sample

Gender	Female	66,8%
	Male	33,2%
Age	20 – 30 years	2,8%
	30 – 40 years	22,0%
	40 – 5 years	49,1%
	50 – 60 years	26,2%
Experience	Less than 2 years	7,9%
	2 - 5 years	28,5%
	5 - 10 years	20,1%
	10 - 15 years	16,8%
Education	More than 15 years	26,6%
	Primary	13,1%
	Secondary	53,3%
Function	Superior	33,6%
	Literary	57,0%
	Computer science	4,7%
	Management, Commercial or Marketing	8,4%
	Scientific or Technical	2,3%
	Legal or Accounting	7,5%
	Economic	20,1%

Sources: developed by the authors.

Against (22.4%) are in the chemical sectors and finally (17.8%) of companies are in the Materials and Manufacturing, Ceramics and Glass activity sectors. It means that most of the companies in the sample belong to different industries. So, it can expect superior performance from these companies.

Table 2. Characteristics of the corporate

Activity Area	Food industry	30,4%
	Chemistry	22,4%
	Leather and Shoes	4,2%
	Textile and Clothing	5,6%
	Wood, Cork and Furniture	7,5%
	Electricity, Electronics and Household Appliances	8,4%
	Mechanics and Metallurgy	3,7%
	Materials and Manufacturing, Ceramics and Glass	17,8%
Nature of the ERP	SAP	25,2%
	Savision	1,4%
	Sage Human Resources	2,8%
	Oracle	4,7%
	Ciel	17,8%
	Adonix	18,2%
	BAAN	22,4%
	Sage Accounting	0,5%
ODOO	7,0%	

Sources: developed by the authors.

In this context, the majority of companies belong to the industrial sectors. In turn, a minority of companies belong to the non-industrial sectors. Regarding to the nature of Enterprise Resource Planning (ERP) of the companies, 25.2% of them had SAP nature, 22.4% – BAAN nature, 18.2% – Adonix nature, and 17.8% – Ciel nature. Subsequently, it can be stated that the choice of nature of the bread-making of the business resources studied in the sample is concentrated on these resources.

Results. This paper carried out an exploratory factor analysis using the principal component analysis to ensure that the data can be factorized and to determine the experimental reliability of the user satisfaction scale. The first PCA with a varimax rotation allowed keeping all items presented strong representation qualities and greater than 0.5. So, the analysis of PCA gave rise to factorial contributions, qualities of representation and satisfactory reliability (Table 3). Analysis of the results of the exploratory factor analysis performed on the user satisfaction scale enabled us to conclude that:

Table 3. Results of the exploratory factor analysis performed on the user satisfaction scale

The items	The quality of representation	Factorial contributions
SATISF1 In your area of responsibility, is the system adapted to your information needs?	0,773	0,879
SATISF2 Does the system help you achieve your work goals?	0,793	0,890
SATISF3 Does the system allow you to reach your goals while optimizing your efforts?	0,816	0,904
SATISF4 Overall as a user, are you satisfied with the system?	0,643	0,802
KMO = 0,756 ; Meaning of Bartlett's sphericity test = 0,000		
Eigenvalues (λ) = 3,026		
Percentage of variance explained = 75,638		
Reliability (Cronbach's Alpha) = 0,892		

Sources: developed by the authors.

The KMO measurement (Kaiser Meyer Olkin) and the Bartlett test (KMO = 0.756; p = 0.000), indicating acceptable values, confirm the factoring of the data. The values of the qualities of representation and those of factorial contributions are satisfactory since they are greater than 0.5.

The user satisfaction scale presents a one-dimensional factor structure. Indeed, the percentage of the variance explained (which is equal to 75.638%) made it possible to retain a single factor with an eigenvalue greater than 1. The items satisfaction means SATISF1, SATISF2, SATISF3 and SATISF4 are grouped under the dimension «User satisfaction». Cronbach's alpha indices, which indicate reliability at the exploratory level, reveal good internal consistency in the user satisfaction scale.

Table 4. Adjustment indices for user satisfaction

Index	Standardized chisquare	GFI Goodness of-fit statistic	AGF adjusted goodness-of-fit statistic	RMR Root mean square residual	RMSEA Root mean square error of approximation	NFI Normed-fit index	CFI Comparative fit index	TLI Tucker-Lewis index
Values	2,603	0,988	0,940	0,032	0,087	0,961	0,975	0,925

Sources: developed by the authors.

It performed a confirmatory factor analysis in addition to the exploratory factor analysis on the user satisfaction scale. The AFC results showed that the Kurtosis and Skewness indices respect the thresholds set by empirical work. However, the Mardia index ($M = 5.278$) greatly exceeds the limit set at 3. This paper proposes to present the adjustment indices of the user satisfaction's measurement model in the table below. It will be on generally satisfactory. Moreover, the values of the adjustment indices and those of the factor contributions expect the minimum threshold recommended in empirical work.

The validation of the measurement model consists of ensuring reliability at the confirmatory level and the validity of each dimension of user satisfaction. Firstly, it begins by calculating the Rho of Joreskog of each dimension. Joreskog's Rho indices indicate values above the threshold of 0.6 set by Bagozzi and Yi (1988, cited in Akrouf, 2010).

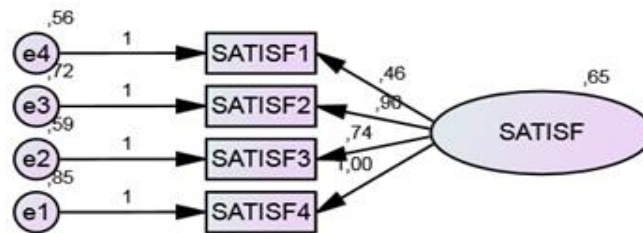

Figure 1. The user satisfaction measurement model

Sources: developed by the authors.

The paper based on the approach of Fornell and Larcker (1981) to calculate the convergent and discriminating validity of each of the dimensions of social relationship management. Table 5 shows acceptable values of the Rho index of convergent validity which are greater than the threshold of 0.5 recommended by Roussel et al. (2002).

Table 5. Reliability and convergent validity of user satisfaction

	Rho of Joreskog	Rho of convergent validity
Satisfaction of users (SATISF)	0,6856	0,6436

Sources: developed by the authors.

An exploratory factor analysis was performed on the information quality scale using PCA with varimax rotation. The results showed that the scale has a factor structure of only one dimension, with a percentage of the explained variance (which is equal to 74.024%) allowed to retain a single factor with an eigenvalue greater than 1. dimension «Quality of information» includes the items QUAIN1, QUAIN2, QUAIN3, QUAIN4, QUAIN5 and QUAIN6

This examination of the values of the quality of representation and those of factorial contributions show that they are satisfactory (greater than 0.5). The KMO measurement and the Bartlett test also indicate acceptable values. Finally, Cronbach's alpha relating to this scale for measuring the quality of information reveals good internal consistency of the scale at the exploratory level. In addition to the exploratory factor analysis, this paper conducted a confirmatory factor analysis on the information quality scale. The AFC results show that the Kurtosis and Skewness indices are within the norm while the Mardia index, which is around 16.245, far exceeds the minimum threshold of 3.

The probability value of Chi-square ($p = 0.000$) obtained by the maximum likelihood method. The information quality measurement model globally presents satisfactory adjustment indexes (see the table below).

Table 6. Results of the exploratory factor analysis performed on the information quality scale

The items		The quality of representation	Factorial contributions
QUAIN1	The information provided by the system is presented in a format suitable for your use.	0,673	0,820
QUAIN2	The information provided is clear.	0,741	0,861
QUAIN3	The information provided is accurate and on time.	0,738	0,859
QUAIN4	Information is updated for decision making.	0,811	0,901
QUAIN5	There are gaps in the information provided.	0,808	0,899
QUAIN6	The content of the information meets your needs.	0,671	0,819
KMO = 0,898; Meaning of Bartlett's sphericity test = 0,000			
Eigenvalues (λ) = 4,441			
Percentage of variance explained = 74,024			
Reliability (Cronbach's Alpha) = 0,925			

Sources: developed by the authors.

However, the normalized Chi-square is around 3.027. This value is lower than the threshold 5 recommended by Marsh and Hocevar (1985) but higher than the maximum limit 3 fixed by several researchers, in particular Carmines and McIver (1981). Thus, it proposed to carry out modifications related to the covariances of the measurement errors to improve the value of normalized Chi-square.

By examining the values of changes in indices (MI) by exchange, this paper found that the most strong modification. It corresponds to the decision to add a covariance link between measurement errors 1 and 4. This modification allowed an improvement in the fit indices and a decrease in the value of normalized Chi-square, as shown in Table 7. Furthermore, it is justified by the similarity of the items QUAIN3 and QUAIN6. Indeed, this research believes that the respondents associated the same answer with QUAIN3 «The information provided is accurate and on time». To that of QUAIN6 «The content of the information meets your needs». Thus, an error of understanding had repercussions on the two answers.

Table 7. Improvement of the adjustment indices of the information quality measurement model

Index	Standardized chi-square	GFI Goodness-of-fit statistic	AGFI adjusted goodness-of-fit statistic	RMR Root mean square residual	RMSEA Root mean square error of approximation	NFI Normed-fit index	CFI Comparative fit index	TLI Tucker-Lewis index
Without modification	3,027	0,960	0,907	0,027	0,098	0,971	0,980	0,967
With modification	1,973	0,976	0,936	0,020	0,068	0,983	0,991	0,984

Sources: developed by the authors.

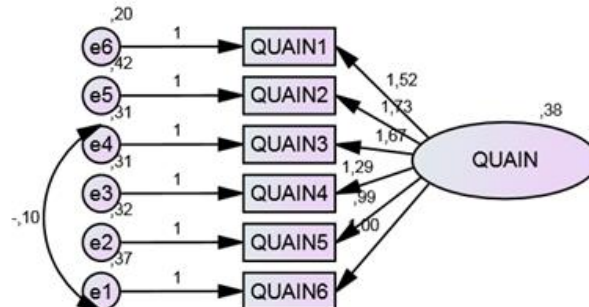

Figure 2. The information quality measurement model

Sources: developed by the authors.

Validation of the measurement model consists of ensuring reliability at the confirmatory level and the convergent validity of the measurement scale for the quality of information. Firstly, it begins by calculating the Rho of Joreskog, which indicates a value above the threshold of 0.6 set by Bagozzi and Yi (1988, cited in Akrouf, 2010). This paper used the approach of Fornell and Larcker (1981) to calculate the convergent validity of the information quality scale. Besides, the convergent validity was checked. The tables below show acceptable values of the Rho index of convergent validity which are greater than the threshold of 0.5 recommended by Roussel et al. (2002).

Table 8. The reliability and convergent validity of the quality of information

	Rho of Joreskog	Rho of convergent validity
Quality of information (QUAIN)	0,6711	0,6710

Sources: developed by the authors.

An exploratory factor analysis was performed on the system quality scale using a PCA with varimax rotation. The KMO measurement (Kaiser Meyer Olkin) and the Bartlett test (KMO = 0.895; p = 0.000), indicating acceptable values, confirm the factoring of the data. The values of the qualities of representation and those of factorial contributions are satisfactory since they are greater than 0.5. The system quality scale has a one-dimensional factor structure, keeping all the items since they have satisfactory qualities of representation and factor contributions. Indeed, the percentage of the variance explained (which is equal to 78.198%) made it possible to retain a single factor with an eigenvalue greater than 1. Observation of the Cronbach's alpha indices of the system quality measurement scale reveals that the scale also has good internal consistency. The table 9 presents the main results of the PCA performed on the system quality scale.

Table 9. Results of the exploratory factor analysis performed on the system quality scale

The items	The quality of representation	Factorial contributions
QUASY1 As a computer tool, is the system easy to learn?	0,782	0,884
QUASY2 Will it be well supported throughout this process?	0,707	0,841
QUASY3 Is the system easy to use?	0,846	0,920
QUASY4 The quality of the system is a powerful determinant of information's systems.	0,845	0,919
QUASY5 The system offers a user-friendly interface.	0,843	0,918
QUASY6 Are there different features of the system?	0,679	0,824

Continued Table 9

QUASY7	I feel frustrated when I use the system.	0,772	0,879
KMO = 0,895; Meaning of Bartlett's sphericity test = 0,000			
Eigenvalues (λ) = 5,474			
Percentage of variance explained = 78,198			
Reliability (Cronbach's Alpha) = 0,952			

Sources: developed by the authors.

In addition to the exploratory factor analysis, it conducted a confirmatory factor analysis on the system quality scale. The results of a first AFC show that the Kurtosis and Skewness indices are within the norm while the Mardia index, which is around 17,072, far exceeds the minimum threshold set at 3. The system quality measurement model does not have the good fit indices. Indeed, the normalized Chi-square largely exceeds the threshold 5 fixed by Marsh and Hocevar (1985 cited in Akrou, 2010). For improving the model, the results make modifications related to the covariances of measurement errors. Due to examining MI values by change, this paper noted that the strongest modification proposed corresponds to add a covariance link between measurement errors 2 and 3; 1 and 6; 4 and 7; 1 and 4. A possible respondents misunderstanding justifies it to items QUASY5 and QUASY6; QUASY7 and QUASY2; QUASY4 and QUASY1; QUASY7 and QUASY4. These changes led to an improvement in the fit indices and a decrease in the value of normalized Chi-square (Table 10).

Table 10. The adjustment indices of the system quality measurement model

Index	Standardized chi-square	GFI Goodness-of-fit statistic	AGFI adjusted goodness-of-fit statistic	RMR Root mean square residual	RMSEA Root mean square error of approximation	NFI Normed-fit index	CFI Comparative fit index	TLI Tucker-Lewis index
Without modification	9,527	0,853	0,706	0,119	0,20	0,629	0,647	0,470
With modification	2,839	0,964	0,901	0,071	0,083	0,921	0,946	0,901

Sources: developed by the authors.

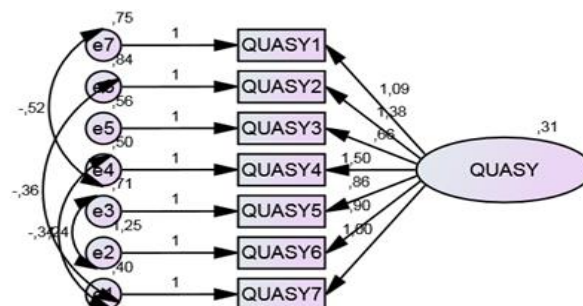

Figure 3. The validation of the system quality measurement model

Sources: developed by the authors.

Validation of the measurement model consists of ensuring reliability at the confirmatory level and the convergent validity of the system quality scale. Firstly, it begins by calculating the Rho of Joreskog, which indicates a value above the threshold of 0.6 set by Bagozzi and Yi (1988, cited in Akrou, 2010). This research used the approach of Fornell and Larker (1981) to calculate the convergent validity of the quality of the system. Herewith, the convergent validity was checked. Tables 11 demonstrates acceptable values of the Rho index of convergent validity which are greater than the threshold of 0.5 recommended by Roussel et al. (2002).

Table 11. Reliability and convergent validity of system quality

	Rho of Joreskog	Rho of convergent validity
Quality of system (QUASY)	0,874	0,538

Sources: developed by the authors.

It performed an exploratory factorial analysis of the utility scale using a principal component analysis. The results allow us to conclude that:

- The KMO measurement and the Bartlett test (KMO = 0.811; p = 0.000), which indicate acceptable values, confirm the factoring of the data.
- The values of the qualities of representation and the factorial contributions are satisfactory (they are all greater than 0.5).
- The utility scale has a one-dimensional factor structure. Indeed, the percentage of the variance explained (76.816%) made it possible to retain a single component with an eigenvalue equal to 3.073.
- Cronbach's alpha (0.897) reveals good internal consistency of the scale.

Table 12. Results of the exploratory factor analysis performed on the utility scale

	The items	The quality of representation	Factorial contributions
UT11	Does the system help you to achieve your work goals?	0,740	0,860
UT12	Does using the system allow you to accomplish the tasks with greater added value?	0,703	0,839
UT13	Does using the system make the job easier?	0,813	0,902
UT14	Does using the system allow you to accomplish your tasks with more excellent added value?	0,816	0,903
KMO = 0,811 ; Meaning of Bartlett's sphericity test = 0,000			
Eigenvalues (λ) = 3,073			
Percentage of variance explained = 76,816			
Reliability (Cronbach's Alpha)= 0,897			

Sources: developed by the authors.

Second, the results of the utility measurement can be useful for a confirmatory factorial analysis on the utility scale. The results of a first CFA show that the Kurtosis and Skewness indices are within the norm while the Mardia index, which is around 5.035, greatly exceeds the minimum threshold set at 3. The utility measurement model generally shows satisfactory fit indexes (see table below). However, the normalized Chi-square is around 3.252. This value is less than the threshold 5 recommended by Marsh and Hocevar (1985 cited in Akrou, 2010), but greater than the maximum limit 3 set by several marketing

researchers, notably Carmines and McIver (1981). Thus, the research proposes to carry out modifications related to the covariances of the measurement errors to improve the value of normalized Chi-square. Looking at the MI values with modification, it will be easier to find that the largest change and corresponds to the decision to add a covariance link between measurement errors 2 and 4. This modification allowed an improvement in the fit indices and a decrease in the value of normalized Chi-square (Table 13). The resemblance of the items UT11 and UT13 justified it.

Table 13. Adjustment indexes for the utility measurement model

Index	Standardized chi-square	GFI Goodness-of-fit statistic	AGFI Adjusted Goodness-of-Fit statistic	RMR Root mean square residual	RMSEA Root mean square error of approximation	NFI Normed-fit index	CFI Comparative fit index	TLI Tucker-Lewis index
Without modification	3,252	0,985	0,927	0,036	0,103	0,939	0,955	0,866
With modification	1,439	0,997	0,966	0,016	0,045	0,987	0,996	0,974

Sources: developed by the authors.

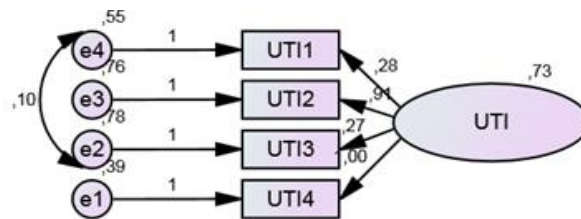

Figure 4. Validation of the utility measurement model

Sources: developed by the authors.

The reliability and convergent validity of scale are very satisfactory with values of 0.7479 for the Rho of Joreskog and 0.549 for the Rho of the convergent validity.

Table 14. Reliability and convergent utility validity

	Rho of Joreskog	Rho of convergent validity
Utility (UT1)	0,7479	0,549

Sources: developed by the authors.

Communication measurement scale. An exploratory factor analysis was performed on the communication scale using PCA with varimax rotation. The measurement of KMO (Kaiser Meyer Olkin) and the Bartlett test (KMO = 0.937; p = 0.000), indicating acceptable values, confirm the factoring of the data. The values of the qualities of representation and those of factorial contributions are satisfactory since they are greater than 0.5. The communication scale has a one-dimensional factor structure. Indeed, the percentage of the explained variance (which is equal to 74.186%) allowed to retain a single factor with an eigenvalue greater than 1. The eight items (COMM1, COMM2, COMM3, COMM4, COMM5, COMM6, COMM7, and COMM8), come together in the same dimension «communication».

Observation of the Cronbach's alpha indices of the communication measurement scale reveals that the scale also has good internal consistency. The table 15 presents the main results of the CPA carried out on the communication scale.

Table 15. Results of the exploratory factor analysis performed on the communication scale

	The items	Quality of representation	Factorial contributions
COMM1	Are the objectives and impacts of ERP implementation communicated to all users?	0,825	0,908
COMM2	The quality of communication plays an important role in the attitude of employees.	0,645	0,803
COMM3	ERP improves communication by facilitating the exchange of information	0,707	0,841
COMM4	Information is entered once, is accessible to all levels of the organization and is available in the real time.	0,699	0,836
COMM5	Is the communication reliable, regular and permanent?	0,793	0,891
COMM6	Is communication constitute a factor to share information in the company?	0,818	0,904
COMM7	Is communication vital for the success of the project?	0,703	0,838
COMM8	Does communication facilitate the dissemination of new information and opportunities to all those involved in the implementation of the integrated management software?	0,745	0,863
KMO = 0,937; Meaning of Bartlett's sphericity test = 0,000			
Eigenvalues (λ) = 5,935			
Percentage of variance explained = 74,186			
Reliability (Cronbach's Alpha)= 0,948			

Sources: developed by the authors.

The communication measurement model. In addition to the exploratory factor analysis, it conducted a confirmatory factor analysis on the communication scale. The results of a first CFA show that the Kurtosis and Skewness indices are within the norm while the Mardia index, which is around 24.397, vastly exceeds the minimum threshold set at 3.

The communication measurement model does not present good fit indices. Indeed, the normalized Chi-square largely exceeds the threshold 5 fixed by Marsh and Hocevar (1985 cited in Akrouf, 2010). It will be useful to make modifications related to the covariances of the measurement errors to improve the model.

Due to examining MI values by change, the research found that the strongest modification proposed corresponds to add a covariance link between measurement errors 1 and 2; 2 and 7; 4 and 5; 5 and 6; 4 and 6. The possible misunderstanding of the respondents to items COMM7 and COMM8; COMM4 and COMM5; COMM3 and COMM4 to items COMM3, COMM5, COMM2 and COMM7 justified it. The latter allowed improving the adjustment indices and a fall in the value of normalized Chi-square (Table 16).

The validation of the communication measurement model. The validation of the measurement model consists of ensuring reliability at the confirmatory level and the validity of the measurement scale of the communication. First of all, the result started by calculating the Joreskog Rho of scale, indicating a value above the threshold of 0.6.

Moreover, the convergent validity has been checked. The tables below show acceptable values of the Rho index of convergent validity which are greater than the threshold of 0.5 recommended by Roussel et al. (2002).

Table 16. Communication model fit indices

Index	Standardized chi-square	GFI Goodness-of-fit statistic	AGFI adjusted goodness-of-fit statistic	RMR Root mean square residual	RMSEA Root mean square error of approximation	NFI Normed-fit index	CFI Comparative fit index	TLI Tucker-Lewis index
Without modification	4,587	0,894	0,809	0,041	0,130	0,942	0,954	0,935
With modification	1,746	0,971	0,931	0,022	0,059	0,983	0,993	0,987

Sources: developed by the authors.

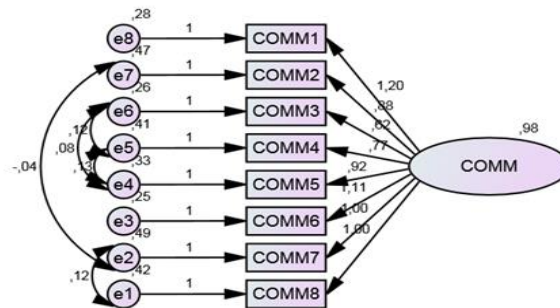

Figure 5. The communication measurement model

Sources: developed by the authors.

The way of the management controller communicates, that is to say that he requests the information he needs and presents his proposal, is a key success factor in the management control process. The new missions assigned to management controllers require mastery of expression techniques. Furthermore, the management controllers must now adopt a language understandable by all actors regardless of their hierarchical level.

Table 17. Reliability and convergent validity of communication

	Rho of Joreskog	Rho of convergent validity
Communication (COMM)	0,8302	0,6922

Sources: developed by the authors.

Analysis of the global measurement model through the examination of the Kurtosis and Skewness indices reveals that they are within the norms. In contrast, the Mardia index, which is around 115.946, far exceeds the minimum threshold set at 3.

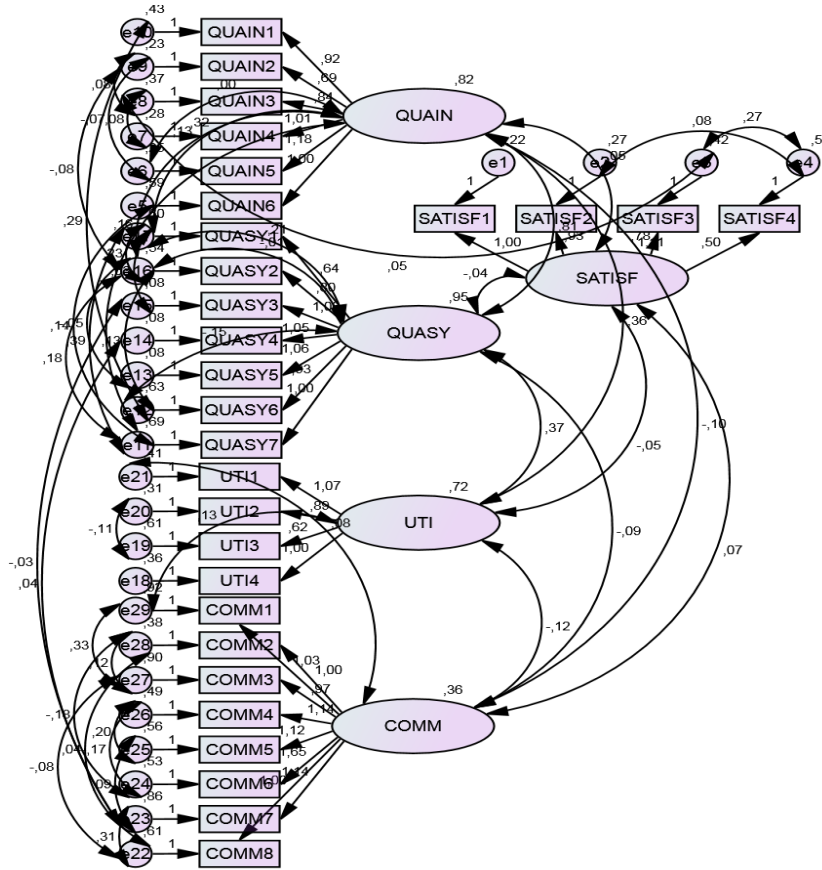

Figure 6. Result of global model

Sources: developed by the authors.

The adjustment indices with the modifications show fairly satisfactory values. However, the values GFI, AGFI, NFI, CFI and TLI tend towards the value of 0.9. However, standardized chi-square has a low value of 1.131. And finally, the values of RMR and RMSEA are within the norms.

Table 18. The adjustment indices of the global measurement model

Index	Standardized chi-square	GFI Goodness-of-fit statistic	AGFI adjusted goodness-of-fit statistic	RMR Root mean square residual	RMSEA Root mean square error of approximation	NFI Normed-fit index	CFI Comparative fit index	TLI Tucker-Lewis index
Without modification	3,046	0,722	0,671	0,067	0,098	0,794	0,851	0,835
With modification	1,131	0,901	0,870	0,058	0,025	0,931	0,991	0,989

Sources: developed by the authors.

The result begins, by calculating the Rho of Joreskog which indicate values above the threshold of 0.6 set by Bagozzi and Yi (1988, cited in Akrouf, 2010) to check the reliability and validity of the overall measurement model. To calculate convergent and discriminant validity, secondly, the results of the research can be useful through the approach of Fornell and Larker (1981). Table 19 and table 20 show acceptable values of the Rho index of convergent validity which are greater than the threshold of 0.5 recommended by Rousset et al. (2002).

Table 19. Reliability and convergent validity of variables in the global measurement model

	Rho of Joreskog ($\rho\xi$)	Rho of convergent validity (pvc)
User satisfaction	0,692	0,640
The quality of information	0,503	0,668
The quality of the system	0,940	0,700
Utility	0,877	0,641
Communication	0,937	0,655

Sources: developed by the authors.

Table 20. The discriminating validity of the measurement model

	User satisfaction	Quality of Information	User satisfaction	Utility	Communication
User satisfaction	0,640				
Quality of information	0,002601	0,668			
User satisfaction	0,001681	0,5184	0,700		
Utility	0,003364	0,221841	0,198916	0,641	
Communication	0,0121	0,030625	0,021316	0,051529	0,655

Sources: developed by the authors.

The methodology adopted to check the discriminant validity consists of reviewing each concept shares more variance with its items than with the other latent variables. Concretely, the discriminant validity is verified when the mean variance extracted (from the latent variable) is greater than the square of the correlation between the variable and the rest of the variable. In the diagonal of Table 20, the variances shared between the constructs and their measurement indicators. The rest of the table corresponds to the squares of the correlations between the different constructs. 0.5184 is correlation square between information and the system quality. Herewith, 0.668 is the average variance extracted between the quality of the information and the quality of the system. All the facts are <0.8. Thus, discriminant validity was verified. All correlation squares (all numbers in Table 20 except those in bold) are less than the average variance extracted (those in bold) (these numbers are all <0.8). The discriminant validity is therefore verified. All the squared correlation coefficients are less than the mean variance extracted. Therefore, the discriminant validity is verified. Validation of the structural equation model. The structural model of this research presents satisfactory fit indices. Indeed, the GFI, AGFI and NFI indices are slightly lower than 0.9 but greater than 0.8, while the CFI and TLI indices are slightly higher than 0.9. The RMR and RMSEA indices have low values and meet the standards (less than 0.08). Finally, the model meets the conditions of parsimony with a normalized Chi-square of a value of 1.934.

The figure of the structural model shows, first of all, that the quality of the system, the quality of information and the usefulness depend positively on user satisfaction. However, the effect of system quality (0.799) is much larger than that of utility (0.536) and quality of information (0.707).

Obtained results allowed concluding that the information system is an essential element of the management process because it presents a fundamental component of the management control system and enables a serious diagnosis to be made using relevant information.

Table 21. Structural model adjustment indices

Index	Standardized chi-square	GFI Goodness-of-fit statistic	AGFI adjusted goodness-of-fit statistic	RMR Root mean square residual	RMSEA Root mean square error of approximation	NFI Normed-fit index	CFI Comparative fit index	TLI Tucker-Lewis index
	1,934	0,844	0,800	0,051	0,066	0,873	0,937	0,925

Sources: developed by the authors.

The table below present the results of the causal links between user satisfaction, quality of the system, quality of information, usefulness and communication.

Table 22. Regression Analysis

Relations	Estimate	SE	CR	P	conclusions
SATISF <--- QUASY	0,799	0,367	4,906	0,000	H1 validated
SATISF <--- UTI	0,536	0,185	2,892	0,004	H2 validated
SATISF <--- COMM	-0,196	0,213	-0,92	0,357	H3 validated
SATISF <--- QUAIN	0,707	1,512	2,451	0,014	H4 validated

Sources: developed by the authors.

So, the final table 22 proves that:

- The first hypothesis of our research, which states that the quality of the system has a positive impact on user satisfaction, has been validated. Indeed, the structural link is significant at the 1% threshold ($t = 4.906 > 1.96$; $p = 0.000 < 0.01$). The regression coefficient between the two variables has a value of 0.799.

- The second hypothesis of this research, which states that utility has a positive impact on user satisfaction, has been validated. Indeed, the structural link is significant at the 1% threshold ($t = 2.892 > 1.96$; $p = 0.004 < 0.01$). The regression coefficient between the two variables has a value of 0.536.

- The third hypothesis of this research, which states that communication has a positive impact on user satisfaction, is not validated. Indeed, the structural link is not significant at the 5% threshold ($t = -0.920 < 1.96$; $p = 0.357 > 0.05$). The regression coefficient between the two variables has a value of -0.196.

- And finally, the fourth hypothesis of this research, which states that the quality of information has a positive impact on user satisfaction, has been validated. Indeed, the structural link is significant at the 5% threshold ($t = 2.451 > 1.96$; $p = 0.014 < 0.05$). The regression coefficient between the two variables has a value of 0.707.

Conclusions. Indeed, the business environment has not stopped experiencing changes and mutations at all levels in recent years, such as economic, sociological or technological, hence the paramount importance granted by firms to information technology and communication to be able to face increased competition and thus improve their competitive positioning. The research empirically confirms and theoretically proves that informational benefits help companies to manage resources better, improve decision-making and planning and also perform better in the departments of the company.

ERP systems could provide information benefits to management using their centralized database and their ability to analyze data. The availability of immediate information and above all, on a national or even international basis, becomes more than necessary. Also, strategic advantages like ERP systems, with their internal and external integration capabilities, will help organizations achieve these strategic benefits.

Integrated IS presented a new opportunity to achieve competitive advantages through the personalization of products and services presented to users (Malone and Yates, 1987; Clemons & McFarlan, 1986) and all other parts of the business, and at low cost. They also facilitate communication between suppliers and customers. At the strategic level, the ERP allows analyzing projects very quickly and guarantee a high quality of information. Thus, it makes possible to determine overall or detailed productivity and to highlight the weak links of the company to improve the whole. Besides, there are some disadvantages and risks to the uses of the information system. Academic publications are therefore broadly part of a structural-functionalist perspective (Bouquin, 1997, Bessire, 2002) and more precisely in the school of objective contingency which refers to elements differentiated from local contexts but which tend to reduce individuals to passive entities (Oriot, 2004). The main factors of resistance to change are the following:

- Mismatch of source/destination data to convert;
- Poor development planning for conversions and interfaces;
- Lack of ERP technical expertise;
- Ignorance of the editor's recommendations during development.

Despite the limitations presented, this work allows us to identify avenues for future research. Indeed, it is possible to study the impact of ERP on the decision-making of the management controller, the practices, the values of the organization and those incorporated in ERP systems, or to move towards the evaluation of the success of ERP systems considered as the new path of «Management Information Systems». This paper considered a more in-depth use of the research variables of this model, in particular concerning the quality of information and communication, which is very important for any organizational project. In future research, it will be essential to introduce other variables deemed useful according to some researchers, notably those relating to culture and user profiles, as it could eliminate redundant ones.

References

- Akrout, F. (2010). Les méthodes des équations structurelles. Sfax: Coopi. [\[Google Scholar\]](#)
- Bailey, J. E., & Pearson, S. W. (1983). Development of a tool for measuring and analyzing computer user satisfaction. *Management science*, 29(5), 530-545. [\[Google Scholar\]](#) [\[CrossRef\]](#)
- Bollecker, M. (2007). La recherche sur les contrôleurs de gestion: état de l'art et perspectives. *Comptabilité-Contrôle-Audit*, 13(1), 87-106. [\[Google Scholar\]](#) [\[CrossRef\]](#)
- Bouquin, H. (1994). *Les fondements du contrôle de gestion*. Presses universitaires de France. [\[Google Scholar\]](#)
- Bagozzi, R. P., & Yi, Y. (1988). On the evaluation of structural equation models. *Journal of the academy of marketing science*, 16(1), 74-94. [\[Google Scholar\]](#) [\[CrossRef\]](#)
- Bagozzi, R. P., & Yi, Y. (2012). Specification, evaluation, and interpretation of structural equation models. *Journal of the academy of marketing science*, 40(1), 8-34. [\[Google Scholar\]](#) [\[CrossRef\]](#)
- Baqlin, G. (2005). *Management industriel et logistique : conception et pilotage de la supply chain*. Paris : Economica.
- BESSIRE, D. (2002). Recherches «critiques» en contrôle de gestion: une typologie. In *Congrès de l'Association Française de Comptabilité (AFC)*. [\[Google Scholar\]](#)
- DeLone, W. H., & McLean, E. R. (1992). Information Systems Success: The Quest for the Dependent Variable. *Information Systems Research*, 3, 60-95. [\[CrossRef\]](#)
- Carmines, E. G. (1981). Analyzing models with unobserved variables. *Social measurement: Current issues*, 80. [\[Google Scholar\]](#)
- Petter, S., DeLone, W., & McLean, E. R. (2013). Information systems success: The quest for the independent variables. *Journal of management information systems*, 29(4), 7-62. [\[Google Scholar\]](#) [\[CrossRef\]](#)
- Bendoly, E., Donohue, K., & Schultz, K. L. (2006). Behavior in operations management: Assessing recent findings and revisiting old assumptions. *Journal of operations management*, 24(6), 737-752. [\[Google Scholar\]](#) [\[CrossRef\]](#)
- Clemons, E. K., & McFarlan, F. W. (1986). Telecom: hook up or lose out. *Harvard Business Review*, 64(4), 91-97. [\[Google Scholar\]](#)
- Fornell, C., & Larcker, D. F. (1981). Evaluating structural equation models with unobservable variables and measurement error. *Journal of marketing research*, 18(1), 39-50. [\[Google Scholar\]](#) [\[CrossRef\]](#)
- Fourati, F. (2010). *Veille stratégique: L'évaluation de l'utilisation des agents intelligents* (Doctoral dissertation, Paris 9). [\[Google Scholar\]](#)

- Granlund, M., & Malmi, T. (2002). Moderate impact of ERPS on management accounting: a lag or permanent outcome?. *Management accounting research*, 13(3), 299-321. [[Google Scholar](#)] [[CrossRef](#)]
- Davis, F. D. (1989). Perceived usefulness, perceived ease of use, and user acceptance of information technology. *MIS quarterly*, 319-340. [[Google Scholar](#)] [[CrossRef](#)]
- Guiot, D. (2002). Méthodes d'équations structurelles: recherche et applications en gestion. *Recherche et Applications en Marketing*, 17(3), 109. [[Google Scholar](#)] [[CrossRef](#)]
- Jones, R. J., & Hu, F. D. (2006). Diet selection of steers grazing *Stylosanthes hamata* cv. Veranoggrass pastures in north Queensland and its potential influence on botanical composition. *Tropical Grasslands*, 40(2), 65. [[Google Scholar](#)]
- Kaplan, S. (1995). The restorative benefits of nature: Toward an integrative framework. *Journal of environmental psychology*, 15(3), 169-182. [[Google Scholar](#)] [[CrossRef](#)]
- Marsh, H. W., & Hocevar, D. (1985). Application of confirmatory factor analysis to the study of self-concept: First-and higher order factor models and their invariance across groups. *Psychological bulletin*, 97(3), 562. [[Google Scholar](#)] [[CrossRef](#)]
- Malone, T. W., & Crowston, K. (1987). J. Yates, RI Benjamin. 1987. *Electronic markets and electronic hierarchies*. *Comm. ACM*, 30(6), 484-497. [[CrossRef](#)]
- Oriot, F. (2004). L'influence des systèmes relationnels d'acteurs sur les pratiques de controle de gestion. *Comptabilité Controle Audit*. [[Google Scholar](#)]
- Davis, G. B., & Olson, M. H. (1985). *Management Information Systems: Conceptual Foundations, Structure, and Development*. New York: McGraw-Hill. [[Google Scholar](#)]
- Reix, R. (2004). *Systèmes d'information et management des organisations*, collection. *Gestion, Vuibert, Paris*.
- Richards, B. (1983). *Unidimensional Scaling* by John P. McIver and Edward G. Carmines. Sage Publications. *Performance & Instruction Journal*, 22(9), 52-52. [[CrossRef](#)]
- Russell, K. A., Siegel, G. H. & Kulesza, C. S. (1999). Counting More, Counting Less: Transformations in the Management Accounting Profession, *Strategic Finance*, 81(3).
- Roussel, P., Durrieu, F., & Campoy, E. (2002). *Méthodes d'équations structurelles: recherche et applications en gestion*. Economica. [[Google Scholar](#)]
- Scapens, R. W., & Jazayeri, M. (2003). ERP systems and management accounting change: opportunities or impacts? A research note. *European accounting review*, 12(1), 201-233. [[Google Scholar](#)] [[CrossRef](#)]
- Seddon, P., & Kiew, M. Y. (1996). A partial test and development of DeLone and McLean's model of IS success. *Australasian Journal of Information Systems*, 4(1). [[Google Scholar](#)] [[CrossRef](#)]

Чіраз Поусси, Dr. Sc., доцент, Університет в Джидда, Саудівська Аравія

Рівень задоволеності користувачів та інформаційні системи: кейс для країн, що розвиваються

У статті висвітлено особливості впровадження інформаційних систем для задоволення потреб компанії. Автор зазначає, що, як правило, впровадження інформаційного забезпечення не є пріоритетним напрямом діяльності компанії. При цьому, інформаційні ресурси повинні збагачувати не лише компанію, але і розповсюджуватись серед споживачів, постачальників, стейкхолдерів та акціонерів. У роботі узагальнено механізм використання інструментарію управлінського програмного забезпечення, яке автоматизує усі функції компанії, а також інтегрує їх для забезпечення процесу виробництва та управління компанією. Головною метою є визначення потенційного впливу управлінської діяльності компанії на якість та рівень задоволення потреб користувачів. Об'єктом дослідження обрано 214 компаній, діяльність, яких пов'язана із інформаційними системами та комунікацією. У роботі автор прийшов до висновку, що корпоративне середовище постійно зазнавало економічних, соціальних та технологічних змін і мутацій. Таким чином, компанії приділяли особливе значення розвитку інформаційних технологій та комунікацій з метою підвищення конкурентних переваг. Емпіричні результати свідчать, що про позитивний статистично значущий вплив ефективності функціонування інформаційних систем в управлінській діяльності компаній на її прибутковість та рівень задоволення її споживачів. Так, інформаційне забезпечення сприяє ефективнішому управлінню ресурсами компанії, удосконаленню процесу прийняття рішень та плануванню, а також покращенню результатів діяльності окремих підрозділів компанії. У статті встановлено, що основною перевагою інформаційної системи планування ресурсів підприємства є формування єдиної бази даних, а також програмного забезпечення для її аналізу. Результати дослідження можуть бути корисними компаніям, які намагаються досягнути стратегічних переваг за допомогою інформаційної системи для комунікації зі споживачами.

Ключові слова: компанія, інформаційні технології, планування ресурсів підприємства, комунікації, якість та користь.

Manuscript received: 14.01.2020

© The author(s) 2020. This article is published with open access at Sumy State University